

# 18 Ο ταλαντευόμενος ανεμιστήρας

## Εισαγωγή

Ο ταλαντευόμενος ανεμιστήρας είναι μια κοινή οικιακή συσκευή που μπορεί να διανέμει ευρύτερα τον άνεμο κουνώντας τα φτερά του. Σε αυτό το μάθημα, θα μάθουμε πώς να φτιάχνουμε έναν ανεμιστήρα που μπορεί αυτόματα να κουνάει και να περιστρέφει τα φτερά του χρησιμοποιώντας το Nezha Inventor's Kit V2.





1

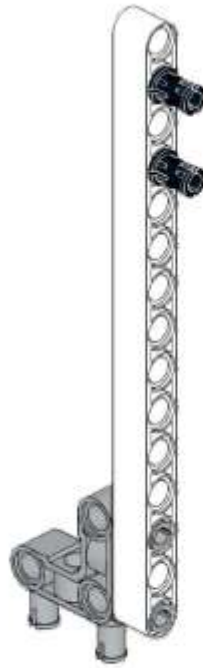
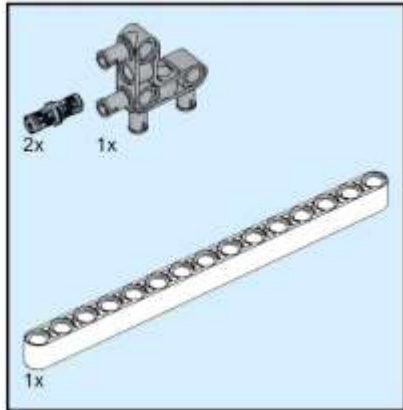

2

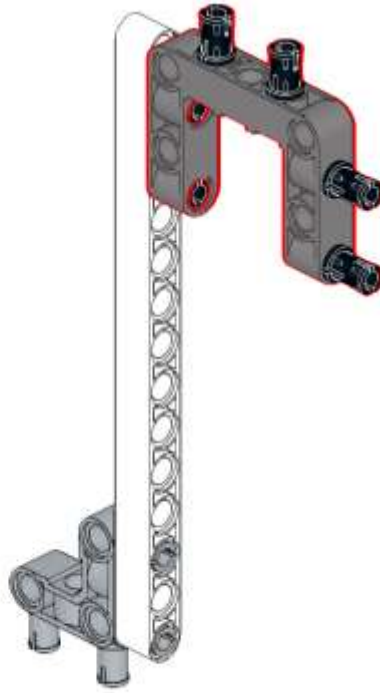
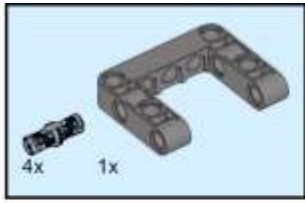

3

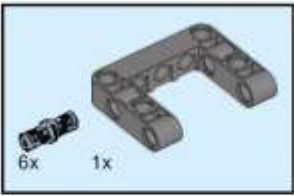

4

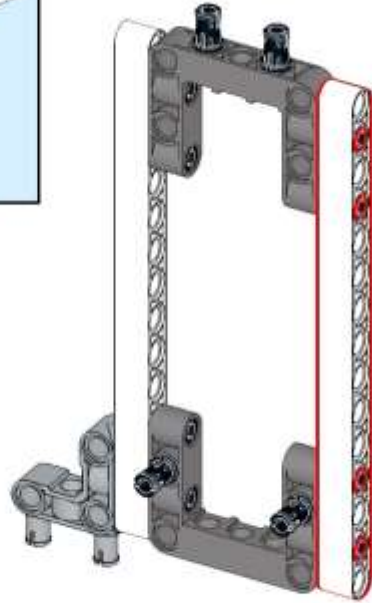
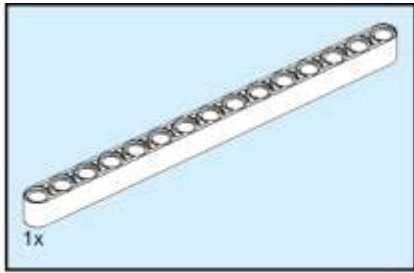

5



6

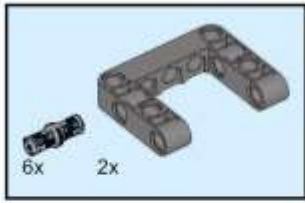

7

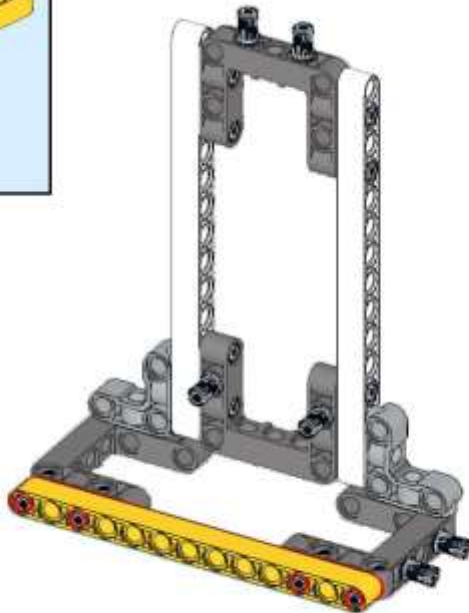
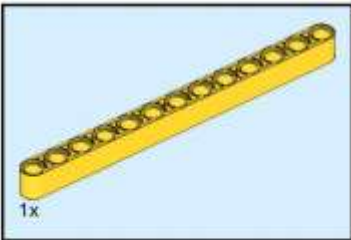

8

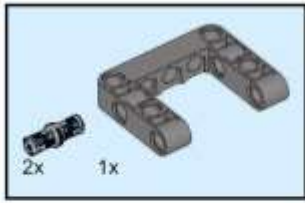

9

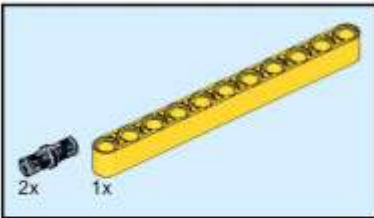

10

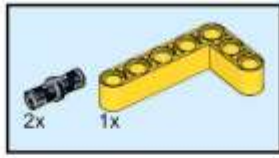

11

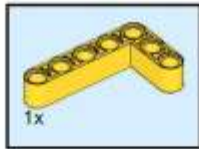

12

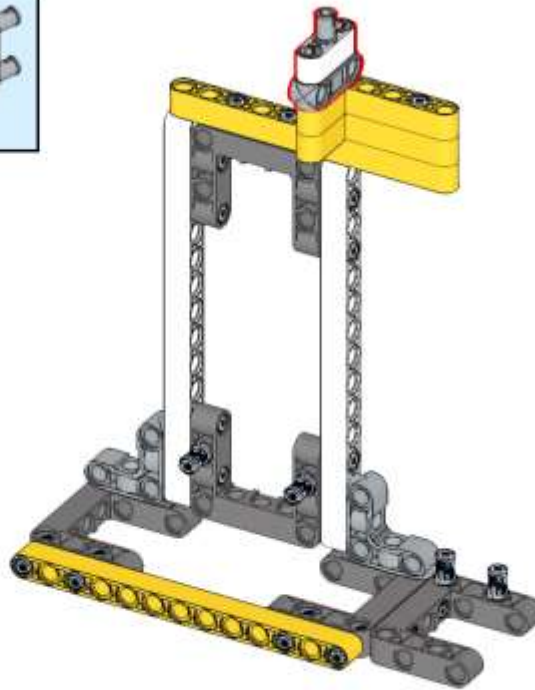
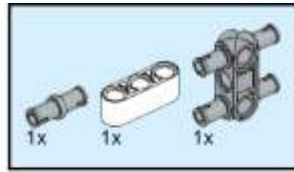

13

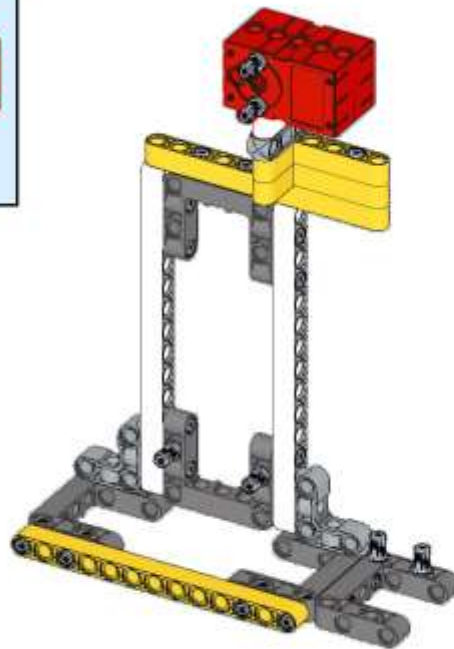
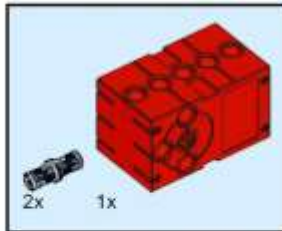

14

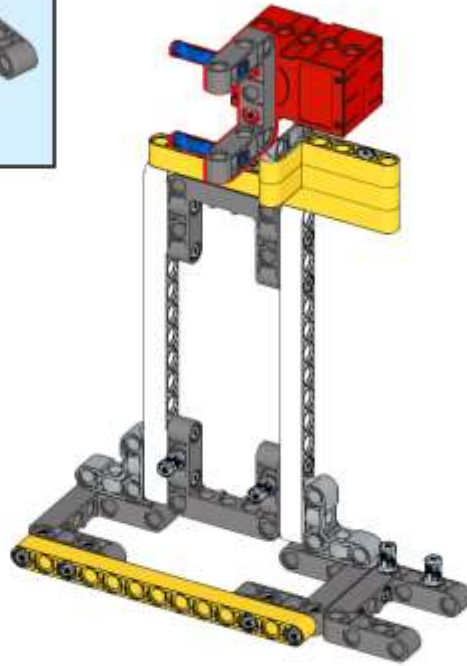
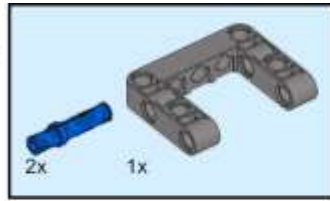

15

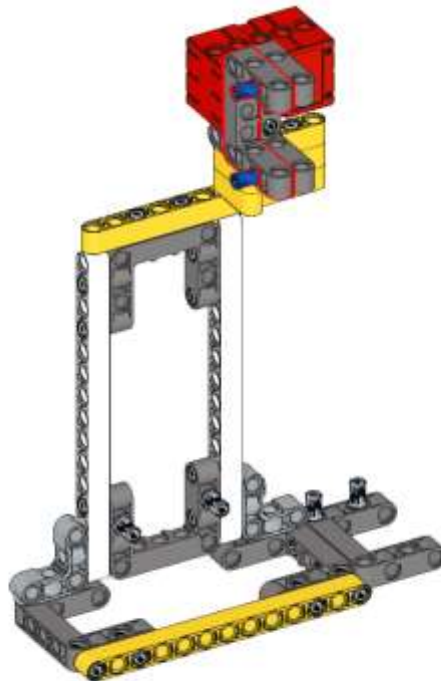

16

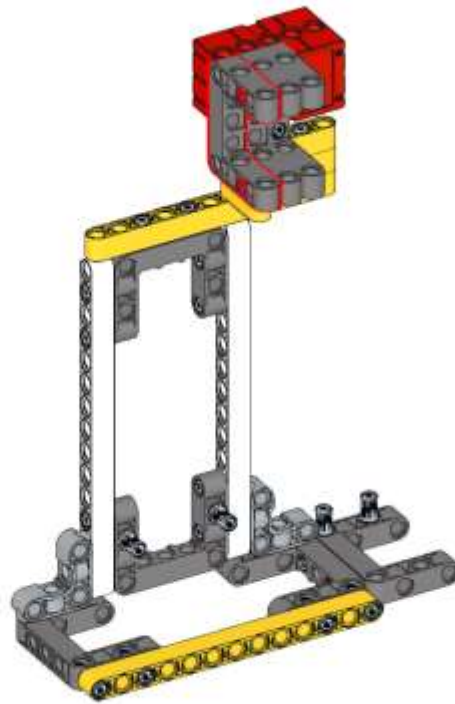

17

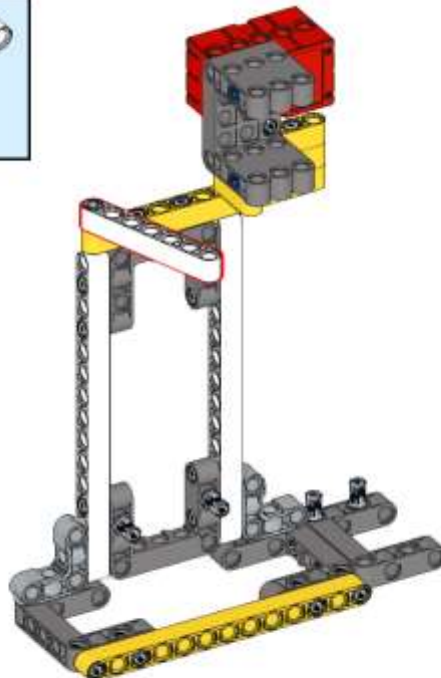
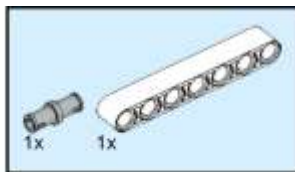

18



19

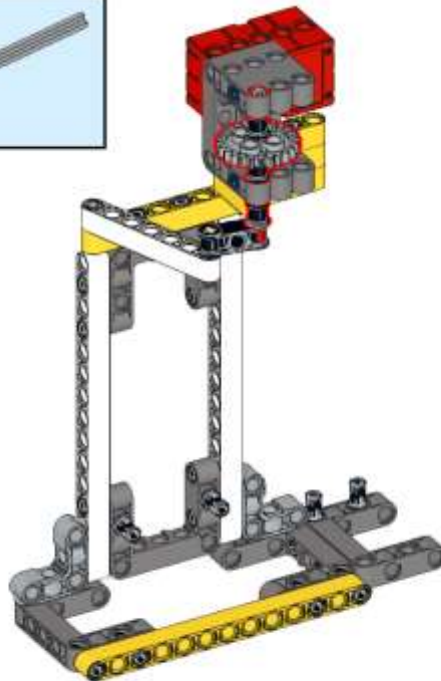
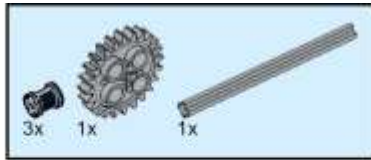

20



21

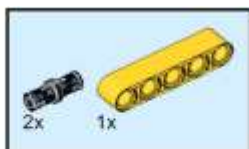

22

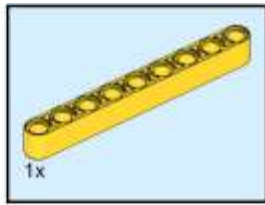

23

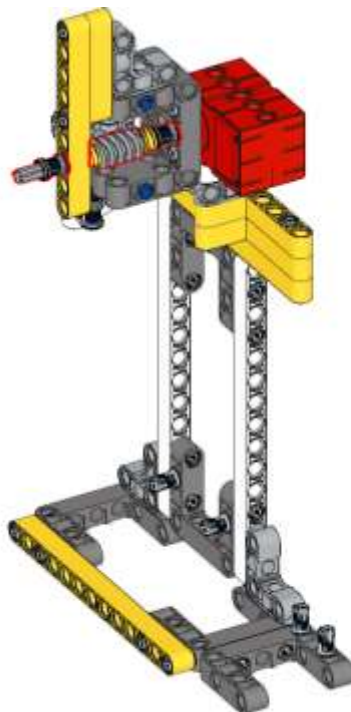

24

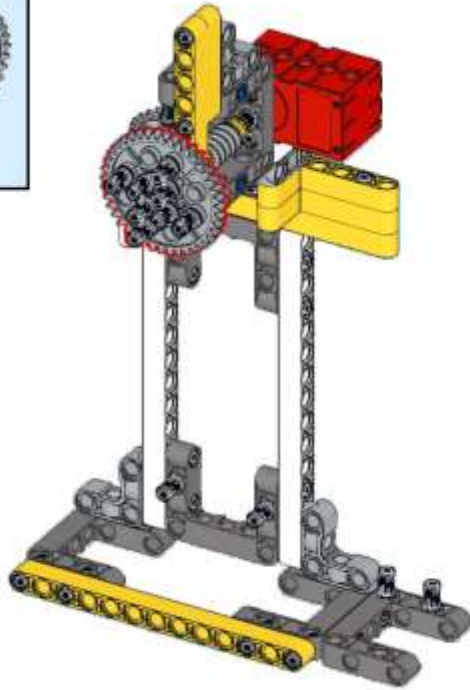
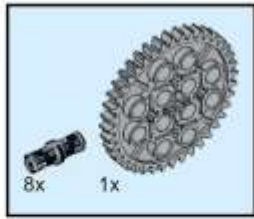

25

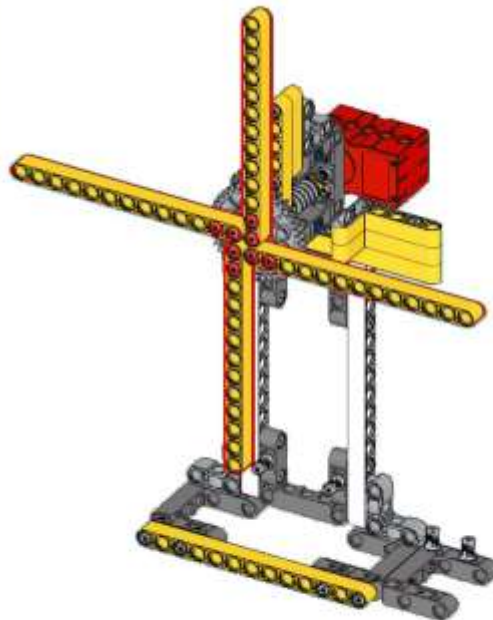
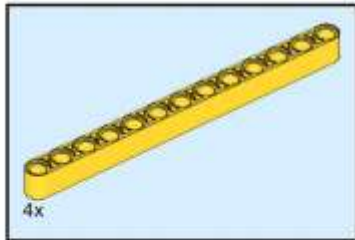

26

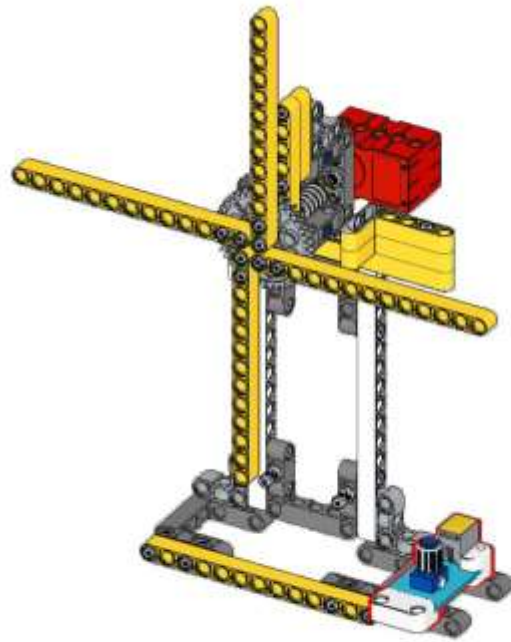
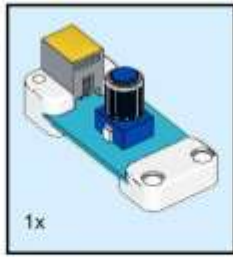

27

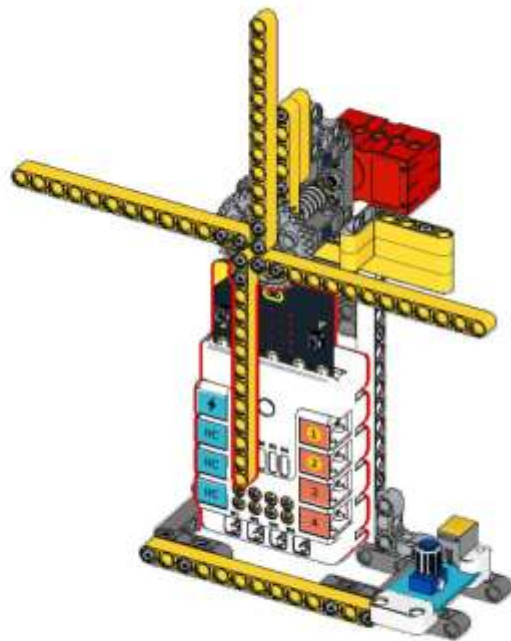
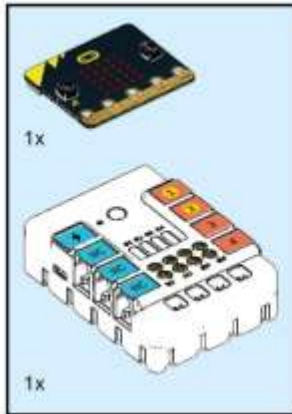

Ολοκληρώθηκε το



#### Συνδέσεις υλικού

Συνδέστε το trimpt στο J1 και τον κινητήρα στο M1 στην πλακέτα επέκτασης Nezha.

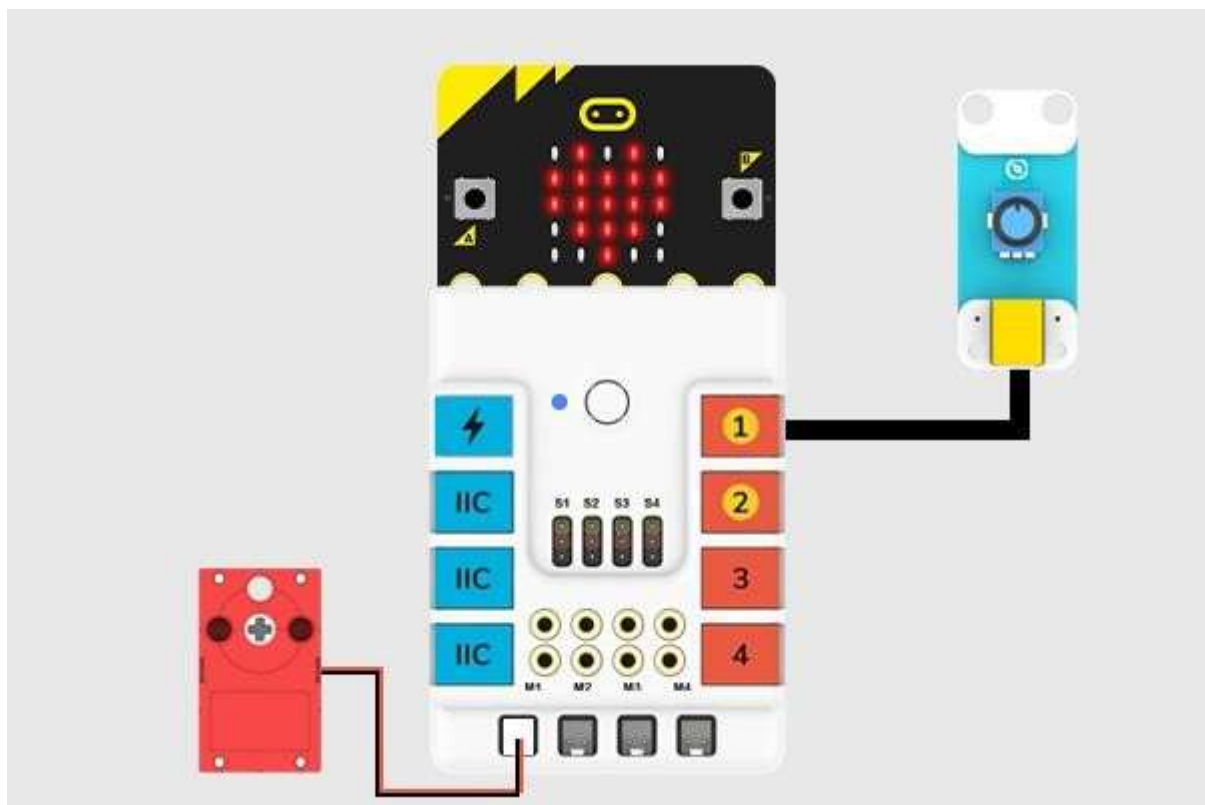

Προγραμματισμός

Μεταβείτε στο [makecode](https://makecode.com)

Δημιουργήστε νέα έργα

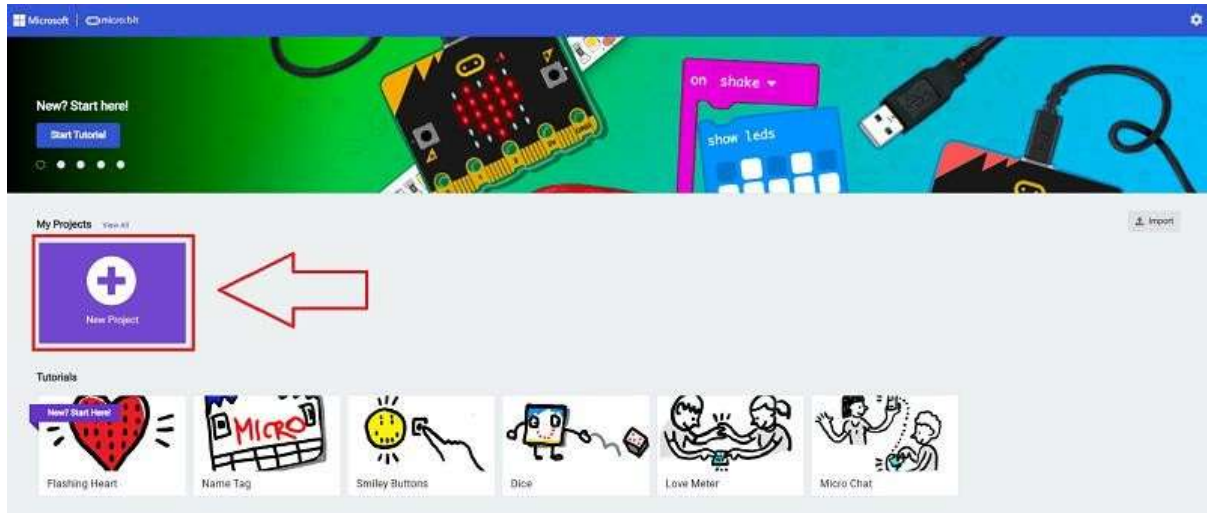

Κάντε κλικ στις επεκτάσεις

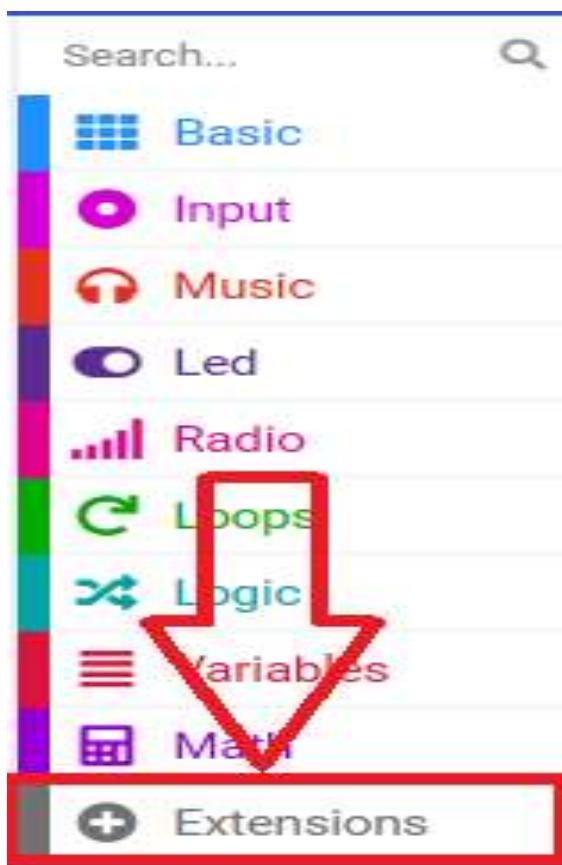

## Αναζήτηση με PlanetX για λήψη του πακέτου.

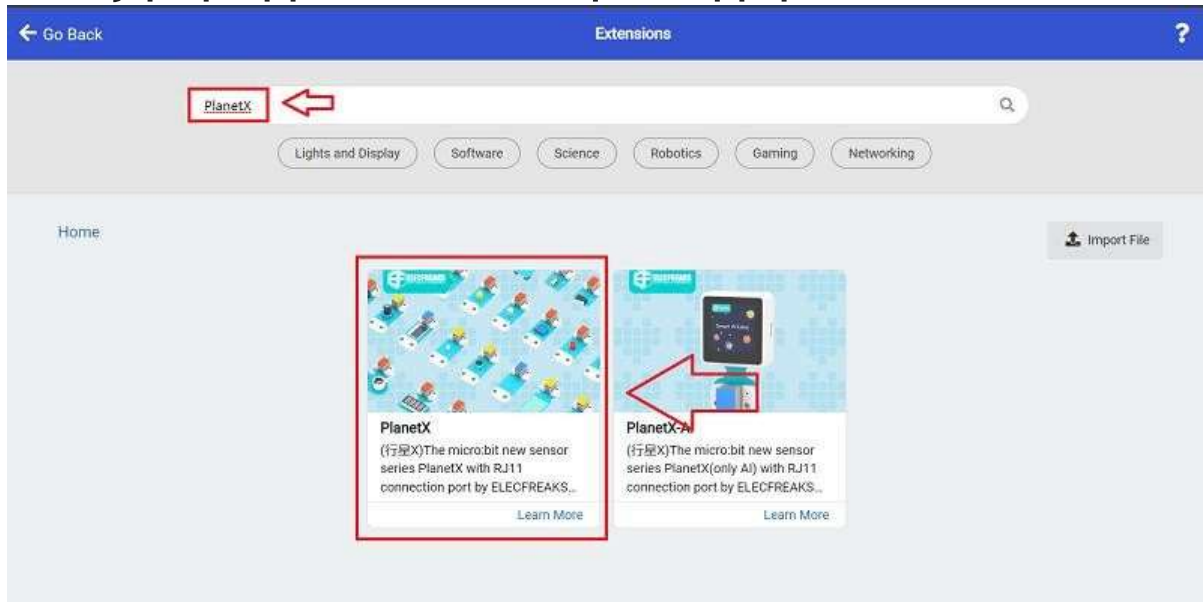

## Αναζήτηση με nezha για λήψη του πακέτου.



### Επίδειξη

Παρουσιάστε σε ομάδες και συγκρίνετε τα αποτελέσματα και την αποτελεσματικότητα κάθε ομάδας.

### Αποτέλεσμα

Η ταχύτητα του ανεμιστήρα ελέγχεται μέσω του trimpot.

